

Threaded Inline Heaters



Designed for Industrial Process Heating Temperatures up to 1400°F (760°C)

Threaded in-line air heaters are UL Recognized products designed for industrial process heating applications requiring high heat and high air pressure. Serpentine™ heating elements are installed into a 304 stainless steel housing and threaded at both ends. TUTCO SureHeat threaded in-line heaters offer two styles, Style “A” and Style “B”. Style “A” should be used when an absolute leak-proof air system is required. Need a custom solution? We have supplied hundreds of customer-specified variations. Contact us for more information.

Features and Benefits

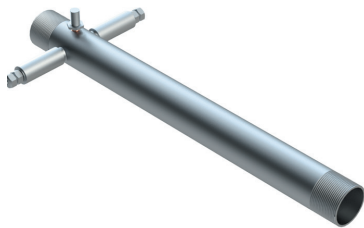

Style A Threaded In-line

- Max inlet temperatures 900°F (482°C)
- UL Recognized
- High-pressure power feed throughs
- Leak-proof to 150 psi (10 bar)



Style B Threaded In-line

- Max inlet temperatures 200°F (93°C)
- UL Recognized
- 12” (305mm) flexible wire power leads
- Not recommended for leak-proof systems due to slight leakage through wire strands

Product Specifications

Maximum Inlet Air Pressure
150 PSI (10 BAR)

Maximum Inlet Air Temperature
900°F (482°C) Style “A”
200°F (93°C) Style “B”

Maximum Exit Air Temperature
1400°F (760°C)

Minimum Air Flow for Best Control
60 SCFM (28 SLPM)



SureHeat® Threaded Inline Products

Size (NPT)	Max. Power	Max.Volts	Max. Amps	P/N, Style “A”	P/N, Style “B”
3/8”	1.6kW	170	9.4	F038821	F038822
1/2”	4.0kW	220	18.2	F038823	F038824
1-1/4”	6.0kW	220	27.3	F038825	F038826
1-1/4”	8.0kW	240	33.3	F077065	F077028
2-1/2”	18.0kW	240	75.0 (1ø)/44.0 (3ø)	N/A	F063007
2-1/2”	18.0kW	480	21.7 (3ø)	N/A	F076418
2-1/2”	24.0kW	240	100.0 (1ø)/57.8 (3ø)	N/A	F074439

Dimensions / Installation Reference

3/8" THREADED INLINES

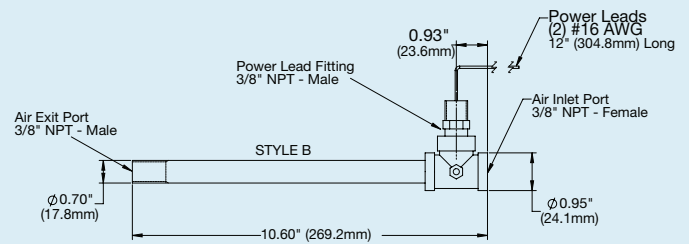
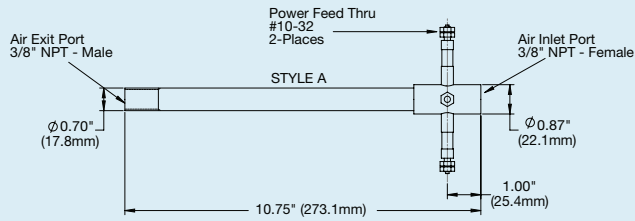

1/2" THREADED INLINES

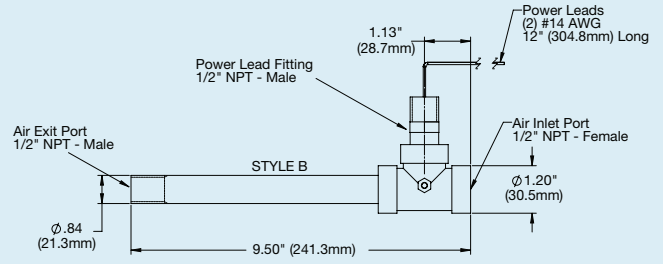
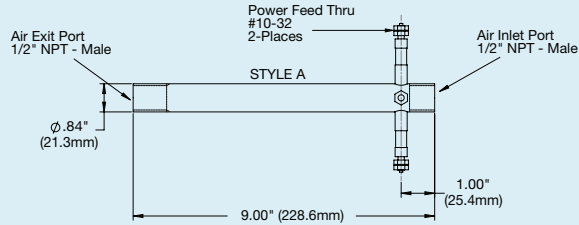

1-1/4" THREADED INLINES

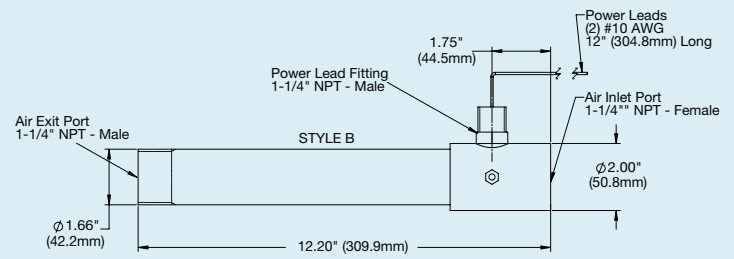
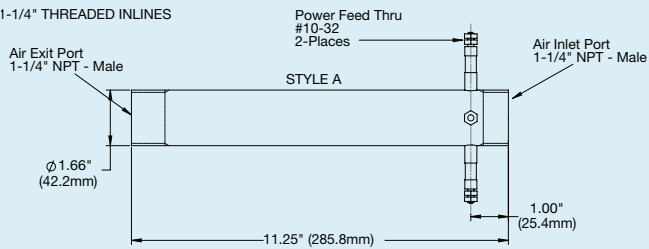

2-1/2" THREADED INLINES

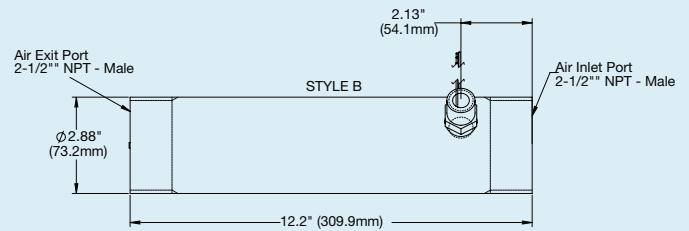
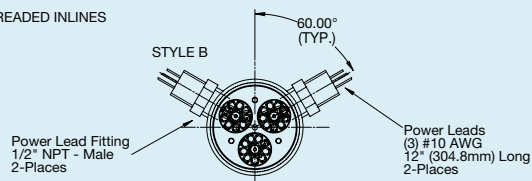

Performance Curves

Threaded Inline Maximum Performance

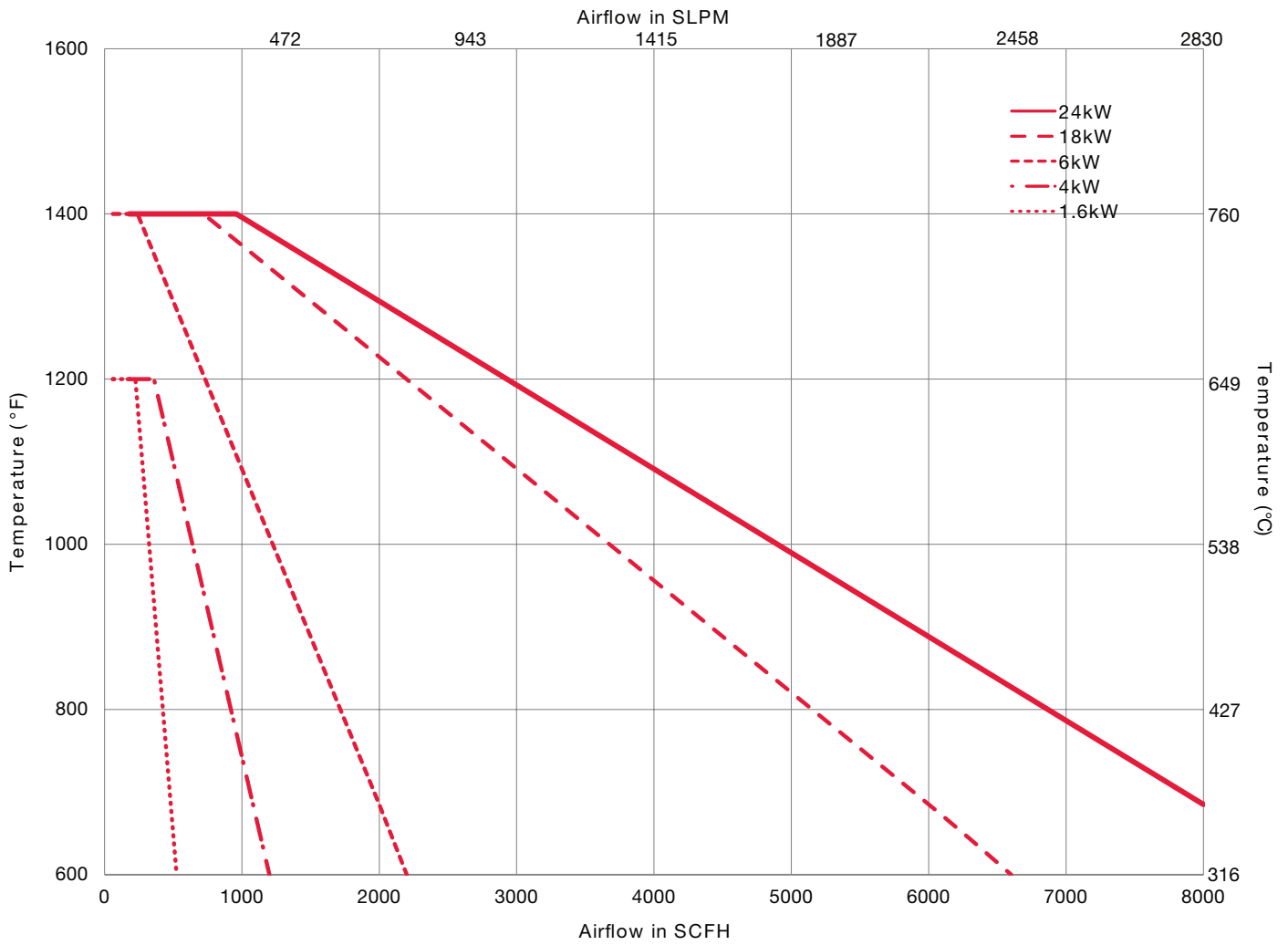

Notes:

- Temperatures are measured by 3/16" "K"
- Use of other sensor types and mounting locations can result in heater damage
- Minimum airflow for accurate control is 60 SCFH
- Maximum air temperature is 1400°F (760°C)
- Operating above this curve voids the product warranty

Threaded Inline Thermocouple Adapters

THREADED INLINE TC ADAPTERS

MODELS NOT TO SCALE

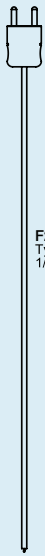

F206119
Type 'K' TC - Exposed Tip
1/8" OD x 12" Long

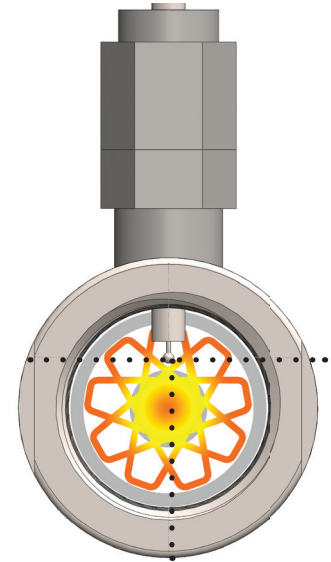
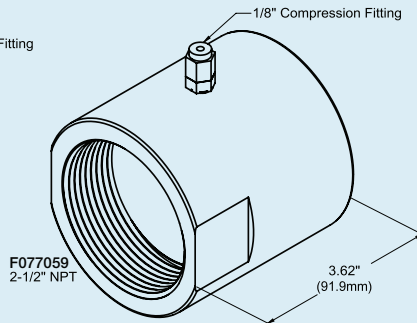
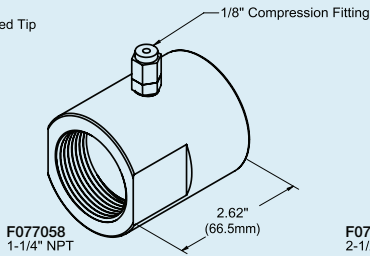
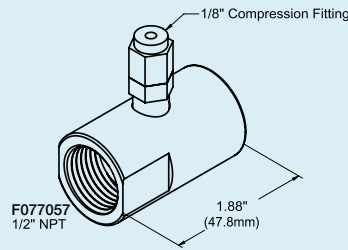
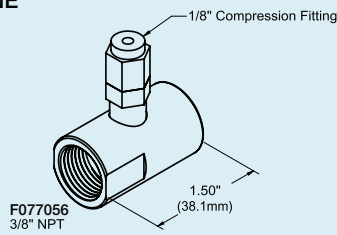

Thermocouple Installation Reference

Before permanently installing an in-line heater, set the depth of the TC compression fitting to ensure proper temperature control.



Make sure to properly mount the TC coupling so that the TC is slightly above the ceramic rod running through the center of the Serpentine™ heating element. The open end of the TC should be in the heated air stream as shown.

Threaded In-Line Thermocouple Adapters

Part Number	Description
F077056	TC Adapter 3/8" Threaded In-Line
F077057	TC Adapter 1/2" Threaded In-Line
F077058	TC Adapter 1-1/4" Threaded In-Line
F077059	TC Adapter 2-1/2" Threaded In-Line
F206119	1/8" TC Type K 12" Probe