

*Serpentine II
and Serpentine VI
Air Heaters*

TUTCO | **SureHeat**

THANK YOU FOR CHOOSING A SERPENTINE HEATER

SERPENTINE II and VI

Compact and efficient process air/inert gas heater, capable of producing exit temperatures up to 1400°F (760°C) with standard elements, and up to 1500°F (815°C) with the “2-Stage” elements. The heater unit consists of two parts - a replaceable serpentine-coil electric heater element, which fits into a stainless steel “triple-pass” exchanger housing. This special housing uses the incoming air to cool the outer shell prior to passing through the heater element. This not only minimizes radiant heat losses but provides a cool outer shell, to minimize burn injury for operators who accidentally contact the heater. Two heater sizes are available; the Serpentine II (wattages from 2000 to 3600W) and the Serpentine VI (wattages from 5000 to 8000W). If operated correctly, element life will be greater than 5000 hours.

SERPENTINE HEATER SPECIFICATIONS

Maximum Inlet Air Pressure	25 PSI (1.7 BAR)*
Maximum Inlet Air Temperature	200°F (93°C)
Maximum Exit Air Temperature	1400°F (760°C) Single Stage 1500°F (815°C) Two-Stage (see page 10 for Performance Curves)
Minimum Airflow (Recommended)	60 SCFH (28 SLPM) for Serpentine II models 120 SCFH (57 SLPM) for Serpentine VI models

GENERAL INFORMATION

Environmental Conditions:

Ambient Temperature	32°F to 104°F (0°C to 40°C)
Humidity	0% to 95% R.H.

Ventilation:

Use in a well-ventilated area away from excess dust, dirt, and moisture.

Cleaning:

With unit OFF and unplugged, exterior surfaces may be wiped clean using a dry, lint-free cloth.

Protective Grounding:

Each heater comes with a convenient grounding stud and hardware located at the inlet of the heater for earth ground.

WARNINGS!



TUTCO SureHeat Process Air Heaters contain high watt-density elements and must be controlled carefully to prevent element failure.

IMPORTANT: Be sure to read and understand this operating manual before turning the system ON. Follow all checklists shown in the manual. Failure to do so can cause a heater failure and may void warranty.

ONLY qualified individuals should install and service this heater and related controls.

Do not hesitate to contact TUTCO SureHeat with any questions
Phone: 1-800-258-8290
E-Mail: support@tutcosureheat.com



ELECTRICAL SHOCK HAZARD!

Follow all applicable electrical codes and use proper wiring.



BURN/FIRE/EXPLOSION HAZARD!

For use with Air or Inert Gases Only -

Do not use with or near explosive or reactive gases.



Avoid contact with the surface of the heater especially the air exit-end during or soon after operation. Depending on the installation location customer may need to install protective screen or guard to prevent injury to personnel and comply with OSHA code.

DO NOT USE NEAR VOLATILE OR COMBUSTIBLE MATERIALS.

HEATER MODELS AND PARTS LIST

Serpentine II Elements (used with Housing/Exchanger Part #F029763)

Part Number	Maximum Watts	Maximum Volts	Maximum Amps	Maximum Pressure (PSI)	Maximum Temperature*
F029765	2000	240	8.3	25	1400°F / 760°C
F029766	2800	240	11.7	25	1400°F / 760°C
F029767	3600	240	15.0	25	1400°F / 760°C
F060418	3600 (2-Stage)	240	15.0	25	1500°F / 815°C

- * Temperatures are measured by 3/16" "K" T/C sensor Part #F039272 mounted inside TC holder #F029485 TC Holder mounted on exit of #F029763 Housing Assembly
- Use of other sensor types and/or locations can result in heater damage if used for process control.
 - Minimum airflow for accurate control is 60 SCFH (28 SLPM)
 - Maximum air temperature is as listed in table above - Operating above this will void warranty

Serpentine VI Elements (used with Housing/Exchanger Part #F057088)

Part Number	Maximum Watts	Maximum Volts	Maximum Amps	Maximum Pressure (PSI)	Maximum Temperature*
F040291	5000	240	20.8	25	1300°F / 705°C
F040292	6000	240	25.0	25	1400°F / 760°C
F061429	6000 (2-Stage)	240	25.0	25	1500°F / 815°C
F056548	8000	240	33.3	25	1400°F / 760°C

- * Temperatures are measured by 3/16" "K" T/C sensor Part #F039272 mounted inside TC holder #F040299 TC Holder mounted on exit of #F057088 Housing Assembly
- Use of other sensor types and/or locations can result in heater damage if used for process control.
 - Minimum airflow for accurate control is 120 SCFH (57 SLPM)
 - Maximum air temperature is as listed in table above - Operating above this will void warranty

DIMENSIONS/MOUNTING

NOTE: The inlet side of the heater is located where the leads/power feedthrus come out of the housing. Failure to install the heater in its proper orientation can result in heater damage and is not covered under the manufacturer’s warranty.

Heater Cartridge:

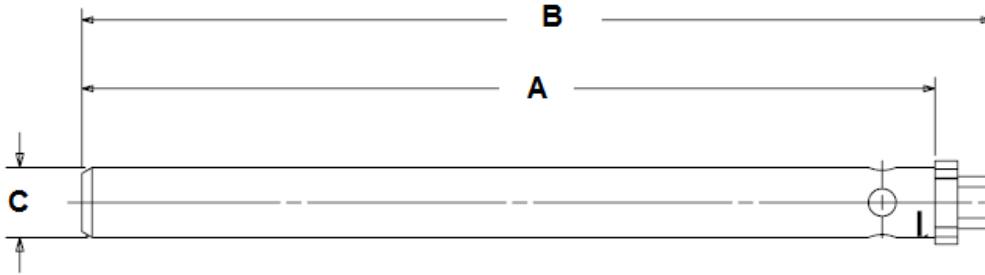

Serpentine II Elements

Part Number	A	B	C
F029765 2.0kW	7.69" (195mm)	8.20" (208mm)	0.63" (16mm)
F029766 2.8kW			
F029767 3.6kW			
F060418 3.6kW	8.13" (206mm)	8.63" (219mm)	0.63" (16mm)

Serpentine VI Elements

Part Number	A	B	C
F040291 5.0kW	10.25" (260mm)	10.88" (276mm)	1.25" (32mm)
F040292 6.0kW			
F061429 6.0kW 2-Stage			
F056548 8.0kW			

Housing Exchanger:

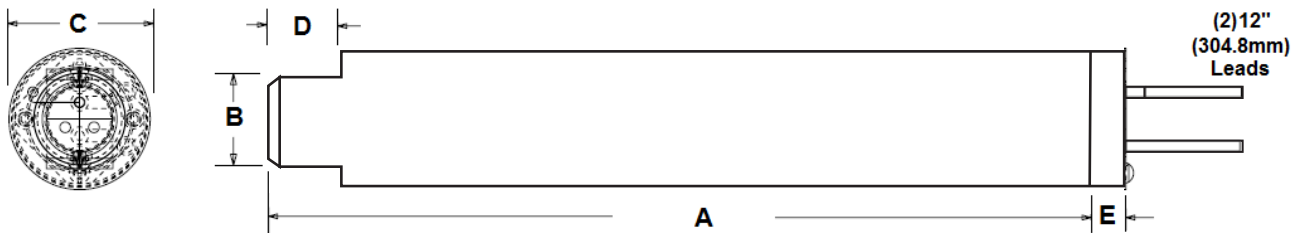

Part Number	A	B	C	D	E	Air Inlet FNPT
Serpentine II F029763	9.63" (245mm)	0.70"Ø (18mm)	1.50"Ø (38mm)	1.00" (25mm)	0.38" (9.5mm)	0.375" (9.5mm)
Serpentine VI F057088	12.38 (314mm)	1.38"Ø (35mm)	2.12"Ø (54mm)	1.00" (25mm)	0.50" (13mm)	0.750" (19mm)

PRECAUTIONS

- 1.** Use filtered air. Avoid grease, oil, or oil vapors, corrosive or reactive gases which will damage heater.
- 2.** Operate at safe voltages as shown on the Performance Curves (see page 8). Excess voltage will cause premature failure.
- 3.** Always have sufficient airflow through the heater before applying power. Otherwise element will overheat very quickly, and burn out. NOTE: A thermocouple cannot detect temperatures if there is no flow – turn on flow before applying power, even when a controller with a thermocouple is being used.
- 4.** Use phase angle fired power controllers. On-off controllers may shorten heater life (or burnout element).
- 5.** For closed-loop control, use exposed junction type “K” thermocouple within one inch of the heater exit.
- 6.** For closed-loop control, use a temperature controller with a fast sampling period (500ms) and minimal overshoot.

INSTALLATION

Caution: DO NOT Operate Heater Without Air



WARNING: THE INLET AIR/GAS SIDE OF THE HEATER IS LOCATED CLOSEST TO WHERE THE POWER FEED-THRU CONNECTIONS ARE MADE. INSTALLING THE HEATER IN THE WRONG ORIENTATION WILL DAMAGE THE HEATER AND CAN CREATE ADDITIONAL HAZARDS AS A RESULT.

1

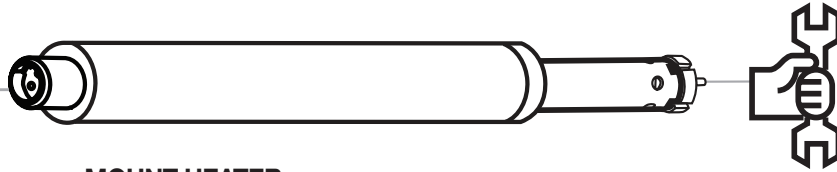

MOUNT HEATER

Securely mount the heater.

2

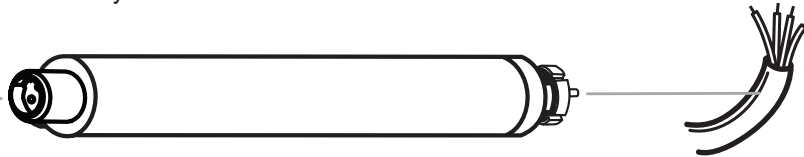

CONNECT GROUNDING WIRE

Connect the ground wire to the green grounding nut on the housing assembly.

3



CONNECT AIR SOURCE TO HEATER

Connect the filtered air source to the heater.

4

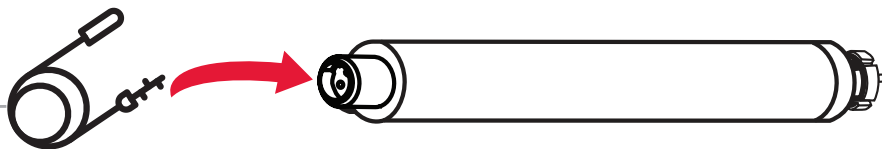

OPTIONAL EXTERNAL THERMOCOUPLE PLACEMENT

If a thermocouple is used, ensure that it is located within one inch from the heater exit. Tutco SureHeat recommends using an exposed junction type K thermocouple like Part # F039272. Contact Tutco SureHeat for specifications.

TYPICAL WIRING

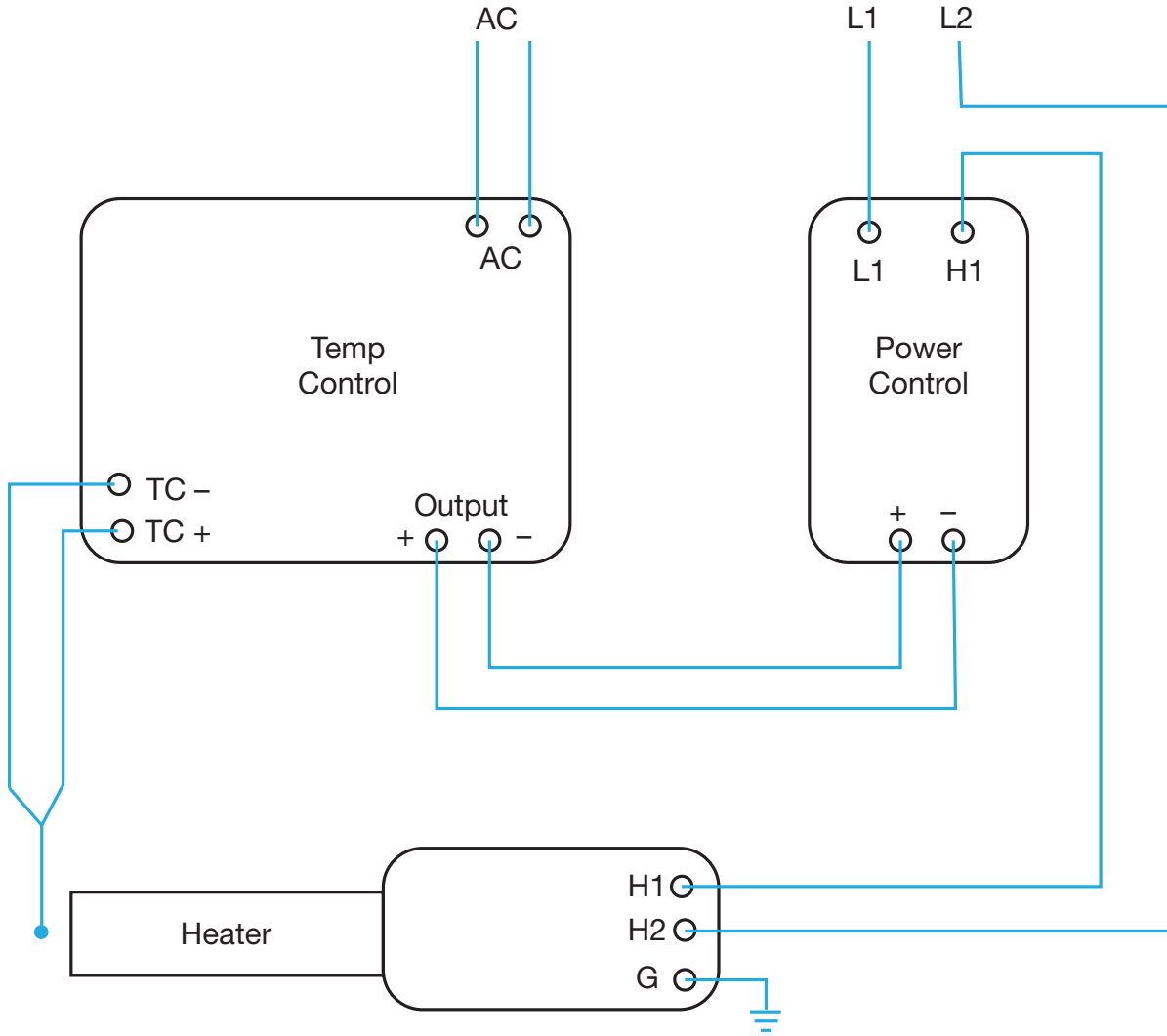

OPERATION

START-UP

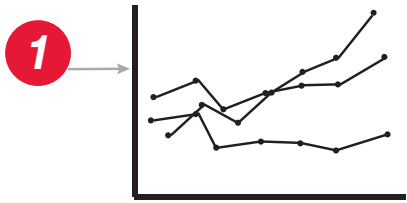

1

REFERENCE PERFORMANCE CURVES
Beginning on page 10 prior to operating heater.

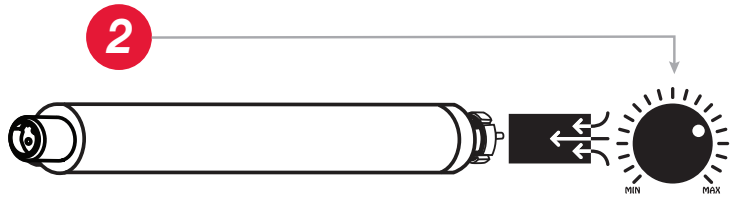

2

TURN ON AIR
Set pressure or flow to desired operating level.

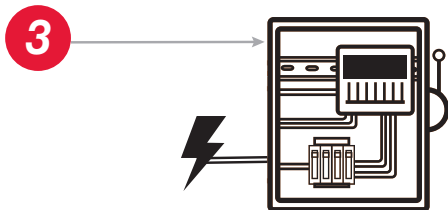

3

ENERGIZE MAIN POWER LINE
Via disconnect switch or circuit breaker on control cabinet.

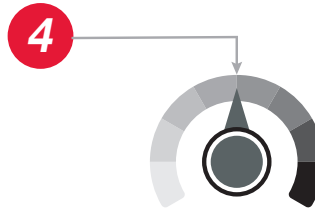

4

SET DESIRED TEMPERATURE

5 **CONTROL AIRFLOW**
Ensure airflow is on before voltage is applied to heater. The heater should NOT be operated with an airflow of less than 1 SCFM or 60 SCFH may cause the heater's element to overheat too quickly and burnout.

6 **CLOSED OR OPEN-LOOP SYSTEM**
If using a closed loop system, turn on power to the temperature and power controller, then set the desired temperature on the temperature controller. If using an open loop system, increase power to the heater through the power controller until the desired temperature is attained.

SHUT-DOWN

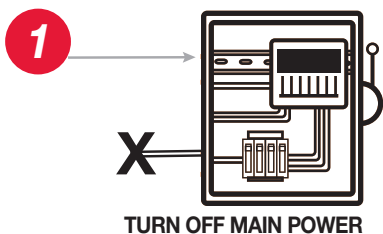

1

TURN OFF MAIN POWER

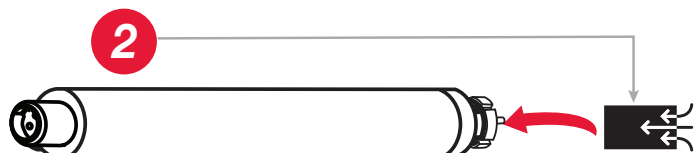

2

CONTINUE AIR FLOW
Allow air to continue to flow for a minimum of 1 minute or until exit air temperature is 300°F/150°C or less for safety. Continue airflow longer as necessary to prevent burn hazard to personnel.

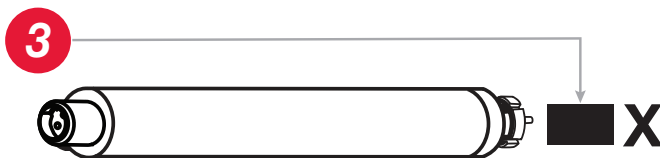

3

TURN OFF AIR TO SYSTEM

PERFORMANCE CURVES

SERPENTINE II ELEMENTS

Serpentine II Maximum Performance
with Baffled Housing (#F029763)

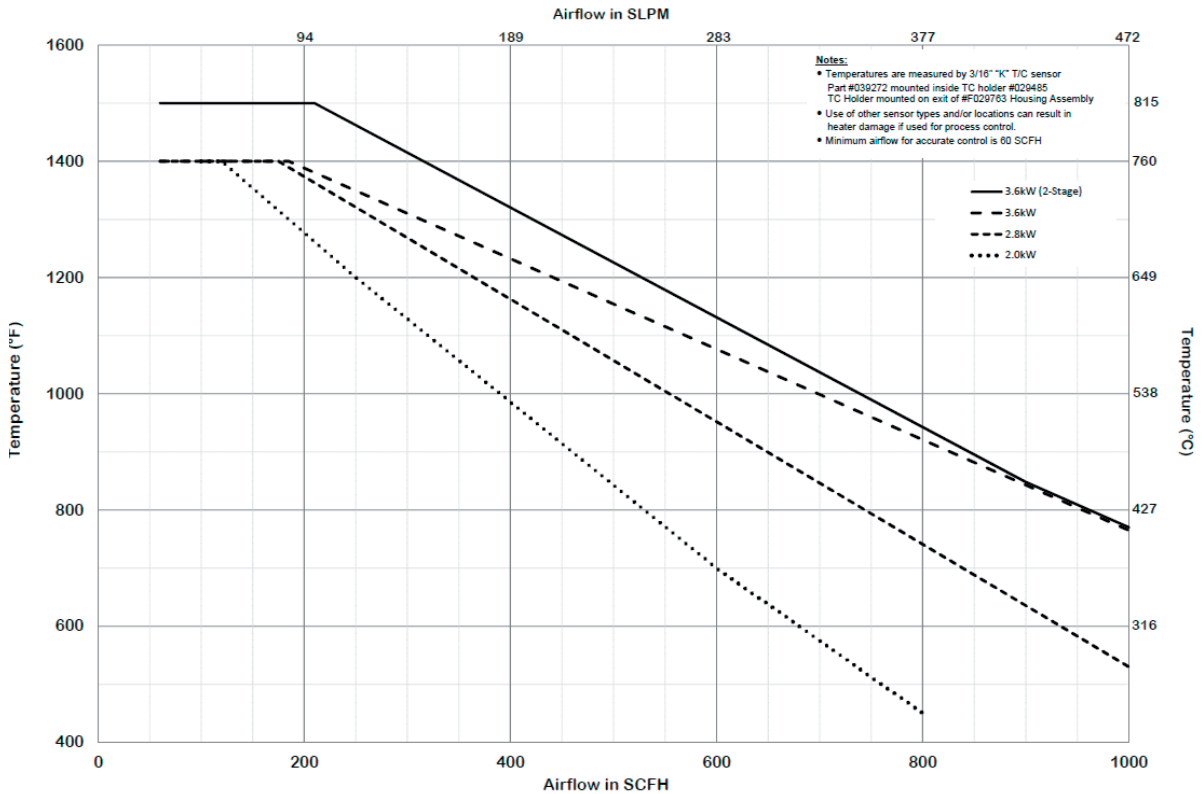

Rev: 03/16

The performance curves on the following pages show exit air temperatures at different airflows and voltages. Pressure readings (longer dashed lines) are measured at the inlet to the heater with no entrance or exit restrictions. Solid lines indicate safe, normal-life operating conditions. The shorter dash lines indicate marginal, shorter-life operating conditions leading to premature burnout. With a known flow (or pressure) at the heater entrance, follow the flow (or pressure) line across until it meets the desired temperature curve. Drop a line straight down to intersect the x-axis. This point, along the "Heater volts – true RMS" axis, represents the voltage required to generate the desired exit air temperature at the chosen flow rate (inlet pressure).

**Serpentine II Performance Curve - 2.0kW
with Baffled Housing (#F029763)**

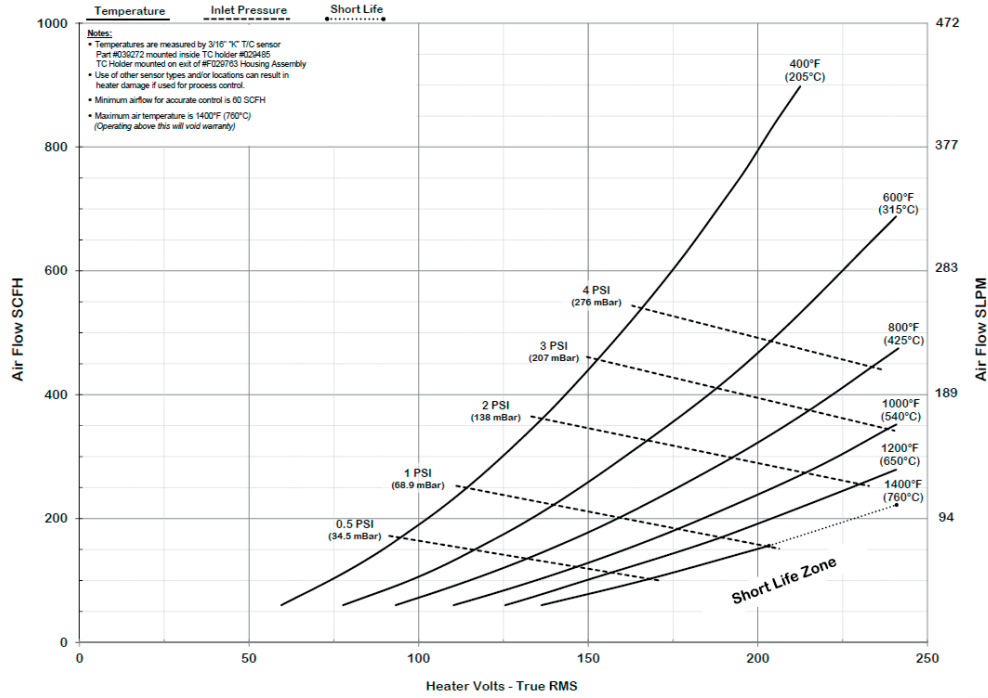

Rev: 03/16

**Serpentine II Performance Curve - 2.8kW
with Baffled Housing (#F029763)**

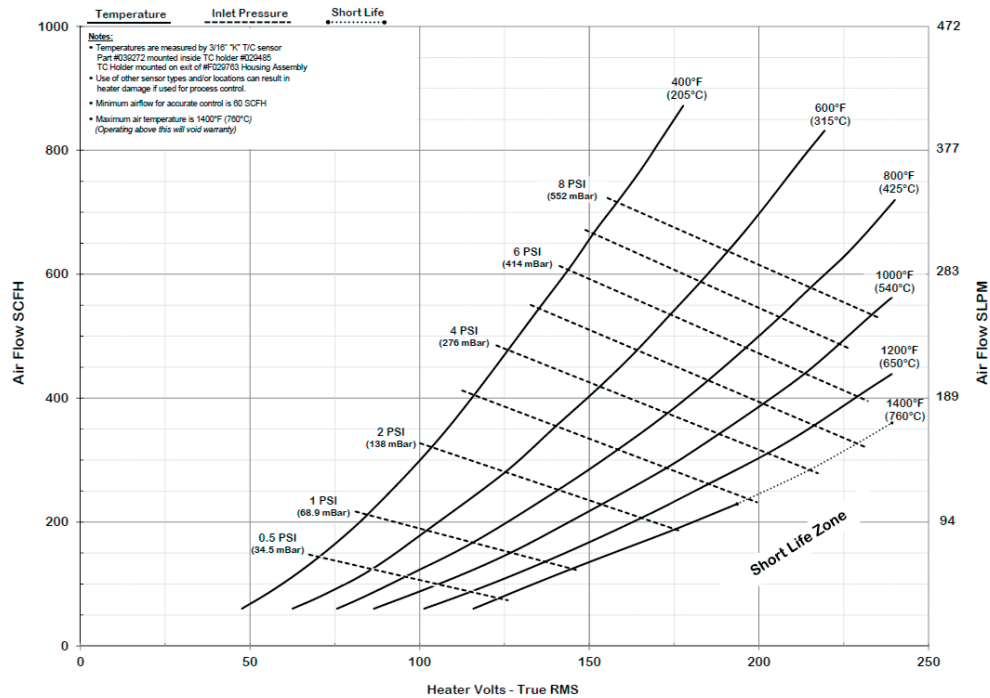

Rev: 03/16

**Serpentine II Performance Curve - 3.6kW
with Baffled Housing (#F029763)**

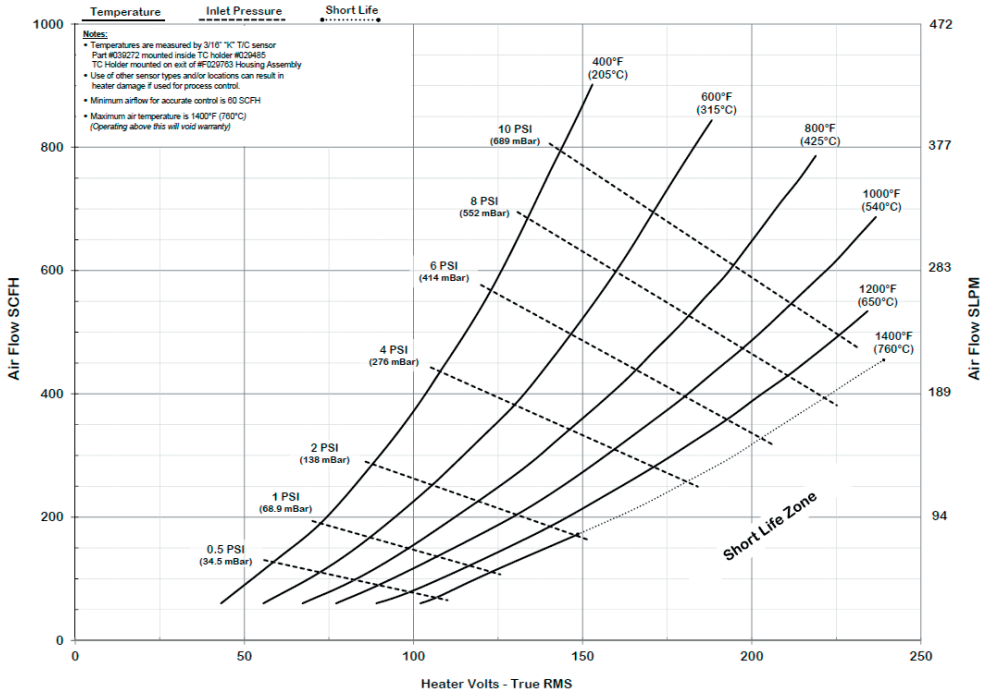

Rev: 03/16

**Serpentine II Performance Curve - 3.6kW (2-Stage)
with Baffled Housing (#F029763)**

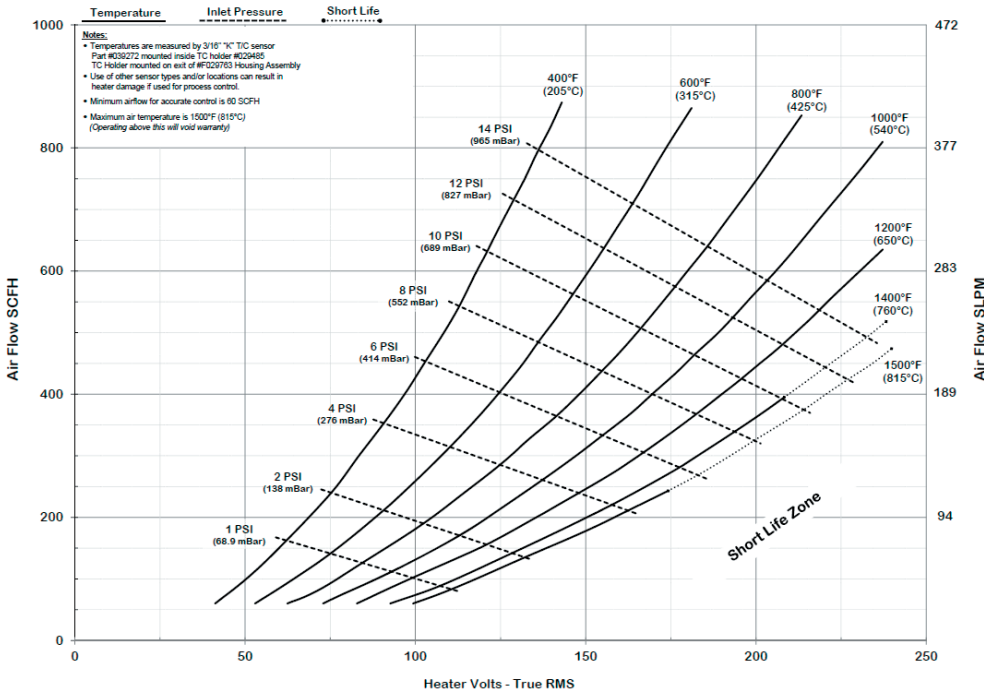

Rev: 03/16

SERPENTINE VI ELEMENTS

**Serpentine VI Maximum Performance
with Baffled Housing (#F057088)**

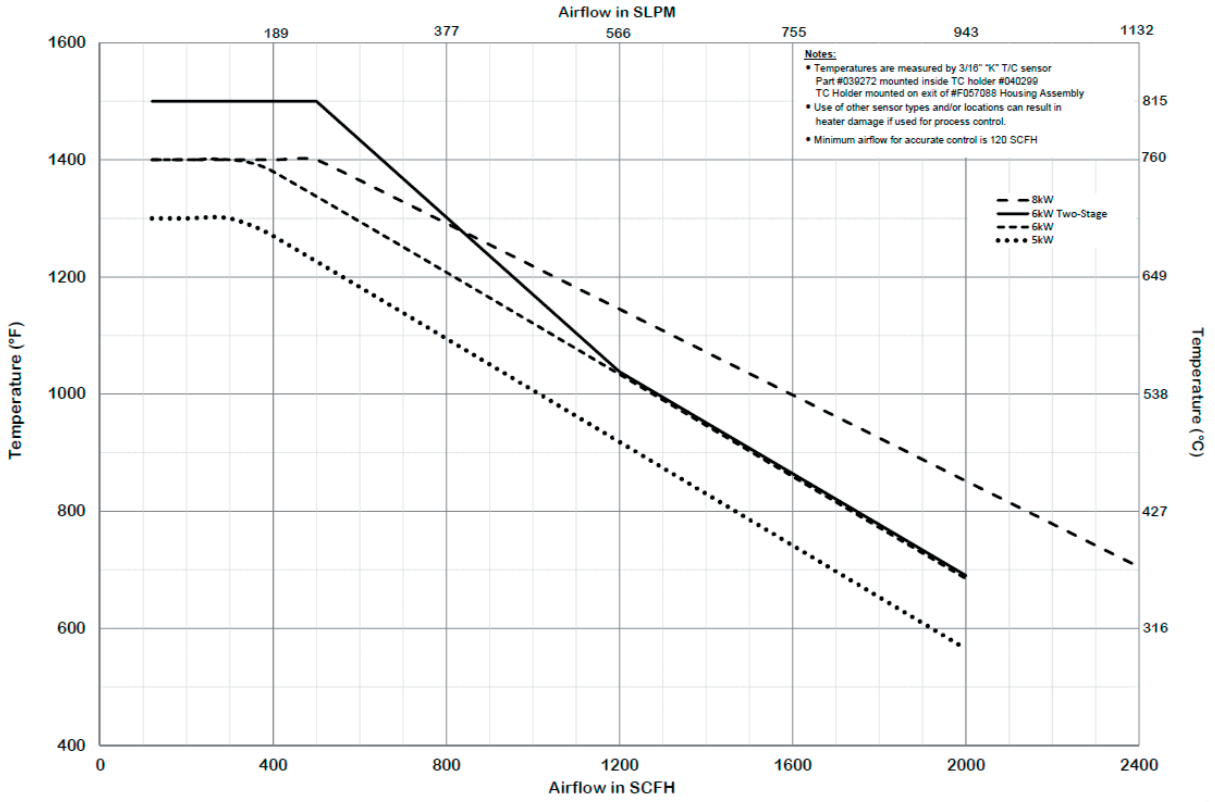

Rev: 03/16

Serpentine VI Performance Curve - 5kW
with Baffled Housing (#F057088)

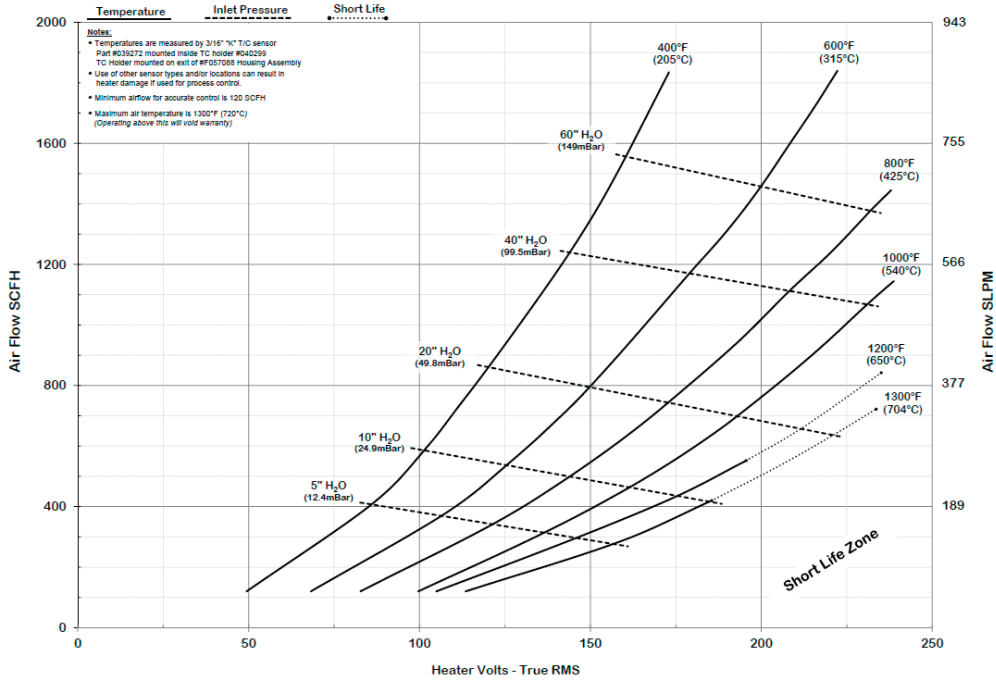

Rev: 03/16

Serpentine VI Performance Curve - 6kW
with Baffled Housing (#F057088)

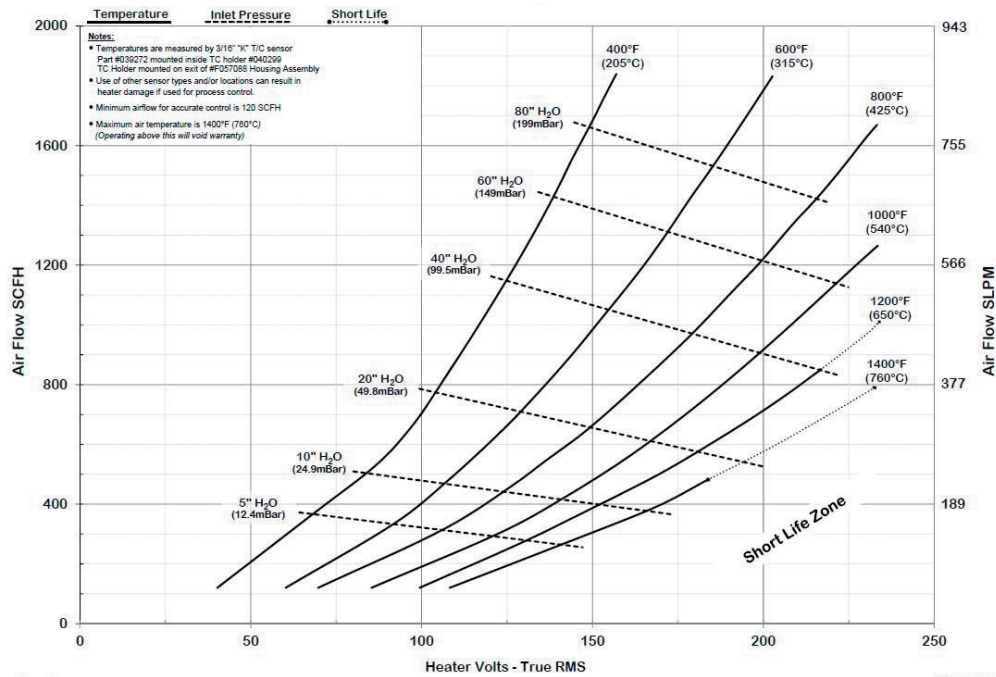

Rev: 03/16

Serpentine VI Performance Curve - 6kW (2-Stage)
with Baffled Housing (#F057088)

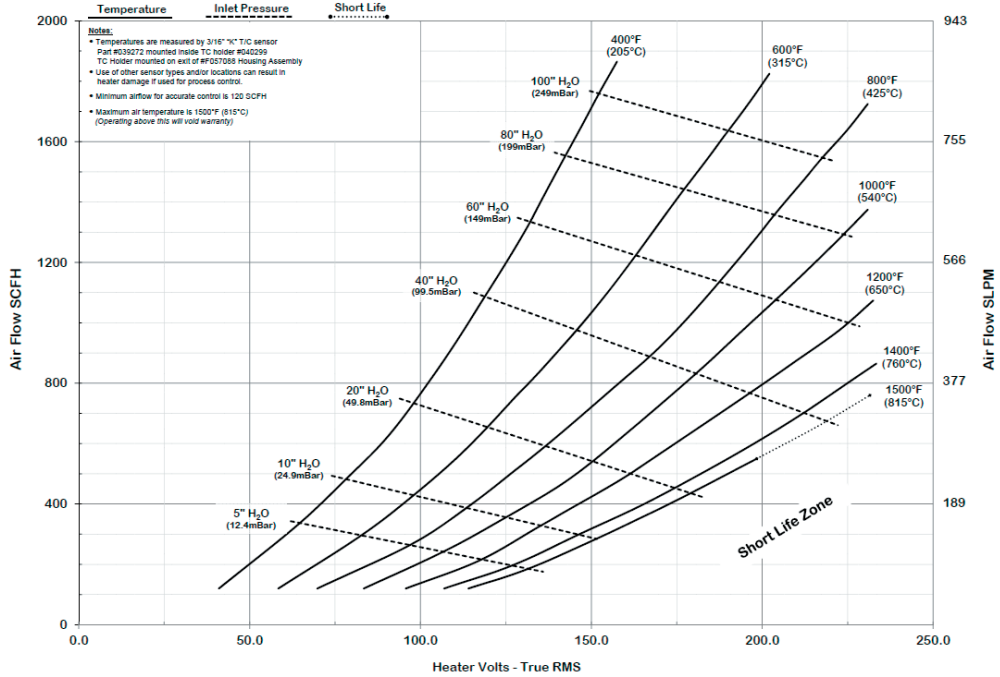

Rev: 03/16

Serpentine VI Performance Curve - 8kW
with Baffled Housing (#F057088)

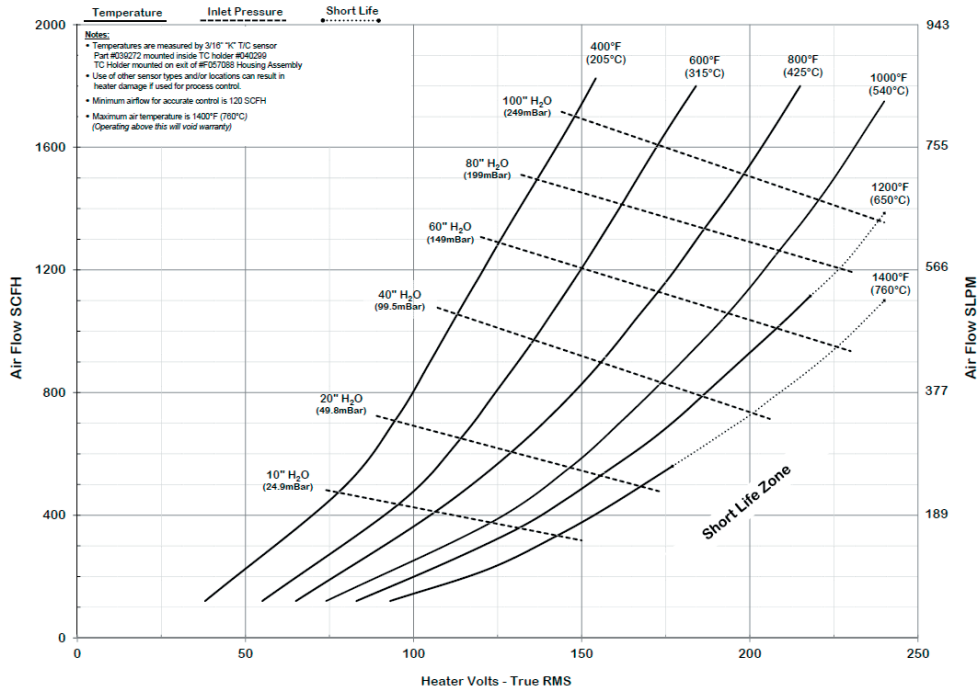

Rev: 03/16

TROUBLESHOOTING AND HEATER REPLACEMENT

- 1.** Note that “TYPICAL” Element Life is APPROXIMATELY 5000 hours. This is based on heater element operating at or below temperatures shown on PERFORMANCE CURVE. In addition to normal end of life, elements can fail due to mechanical damage, or problems with the control system.
- 2.** If an element has failed prematurely, it should be inspected by SureHeat to determine the cause of the element failure.
- 3.** When replacing or troubleshooting heaters, turn off power to the system and be sure to follow lock-out/tag-out procedures.
 - a.** For Troubleshooting Heater
 - i.)** Use multi-meter to check continuity between:
 - 1.** Power terminals H1 to H2
 - 2.** Thermocouples positive (+ yellow) to negative (- red)
 - ii.)** If there is continuity on all above tests, check system wiring:
 - 1.** Crossed thermocouple wires.
 - 2.** Reversed thermocouple wire polarity – Note: RED is NEGATIVE (-).
 - 3.** Verify inlet air temperature is below set point on INLET TEMPERATURE controller.
 - iii.)** If there is no continuity on any test, then contact your local TUTCO SureHeat representative for assistance.
- 4.** Remove entire heater assembly from system. Internal components are typically not replaceable.
- 5.** Reconnect thermocouples, power and ground wires for new/replacement heater.
- 6.** Attach any covers and operate heater per operating manual.

PROPER CONTROL SETUP



- TUTCO SureHeat process air heaters contain high watt-density elements and must be controlled carefully to prevent element failure.
- Sudden applications of power can damage heater and void warranty.
- Following each of these guidelines will help to ensure safe heater operation.

✓ **Start the heater with a 0° (F or C) Set-Point (SV):** This will ensure the output signal to the power control starts off low (0% output) before the contactor is engaged and immediately applying full power.

✓ **Use proper closed loop control (PID) settings.** TUTCO SureHeat typically uses the following PID; Proportional (P), Integral (I) and Derivative (D); settings as a starting point for stable temperature control. Some manual tuning may be required for more precise control.

Description:	Range:	Default:
(P) roportional	90-250	131
(I) ntegral	8-20	9
(D) erivative	0-2	2
Scan/Cycle Rate	< 500mSec	200mSec

✓ **Incorporate a Ramp Rate for the start-up of the heater.** The slower you ramp to your final set-point the less overshoot and problems you will have. Typically TUTCO SureHeat heaters should be ramped up over a period of several minutes. The following are recommended ramp rates based on final temperature. (For custom ramp rates consult with factory)

Set-Point Temperature	Degrees per Minute
Up to 600°F (up to 300°C)	360°F (150°C)
601-1000°F (301-500°C)	240°F (100°C)
1001-1400°F (501-760°C)	120°F (50°C)

LIMITED WARRANTY

TUTCO SureHeat warrants that all products to be delivered hereunder will be free from defects in material and workmanship at the time of delivery. TUTCO SureHeat's obligation under this warranty shall be limited to (at its option) repairing, replacing, or granting a credit at the prices invoiced at the time of shipment for any of said products. This warranty shall not apply to any such products which shall have been repaired or altered, except by TUTCO SureHeat, or which shall have been subjected. TUTCO SureHeat shall be liable under this warranty only if (A) TUTCO SureHeat receives notice of the alleged defect within sixty (60) days after the date of shipment; (B) the adjustment procedure hereinafter provided is followed, and (C) such products are, to TUTCO SureHeat's satisfaction, determined to be defective.

THE WARRANTY SET FORTH IN THE PRECEDING PARAGRAPH IS EXCLUSIVE AND IN LIEU OF ALL OTHER WARRANTIES, EXPRESS OR IMPLIED, INCLUDING, WITHOUT LIMITATION, ANY IMPLIED WARRANTY OF FITNESS FOR A PARTICULAR PURPOSE OR OF MERCHANTABILITY.

The information contained in this manual is based on data considered to be true and accurate. Reasonable precautions for accuracy has been taken in the preparation of this manual, however TUTCO SureHeat assumes no responsibility for any omissions or errors, nor assumes any liability for damages that may result from the use of the product in accordance with the information contained in this manual.

Please direct all warranty/repair requests or inquiries to the place of purchase, and provide the following information, in writing:

- (A) Order number under which products were shipped
- (B) Model/Serial Number of product
- (C) Reason for rejection

PRODUCTS CAN NOT BE RETURNED TO TUTCO SUREHEAT WITHOUT AUTHORIZATION.

Replacement, repair, or credit for products found to be defective will be made by the place of purchase. All products found to be not defective will be returned to the Buyer; transportation charges collect or stored at Buyers expense.



Aerospace Automotive 3D Printing Electronics Medicine Packaging Printing Plastics Textiles

Electric Industrial Air Heaters for Demanding High-Temperature Applications

The technical data and specifications supplied in this operating manual are subject to change without prior notice. Contact TUTCO SureHeat for additional assistance.



603-418-7662

support@tutcosureheat.com orders@tutcosureheat.com

22 Industrial Drive Exeter, NH 03833 USA